

PCM Service Update

Coast Guard Safety Recall

8.1L Wiring Harness Modification

Engines Affected:	8.1L	Serial Numbers Affected:	2001	415153-415308
	8.1L H.O.		2002	425019-425407
			2003	435002-435003

Coast Guard Safety Recall #020174S addresses a possible safety issue with the 8.1L and 8.1L HO engine wiring harness. The condition associated with this recall is the possible melting of the wiring harness. **Engines equipped with a Balmar 100 amp alternator are not effected.**

- A - Charging Circuit Modification**
(Coast Guard Safety Recall #020174S)
 - 6 Gauge Fused Wire From Starter Solenoid to Circuit Breaker/6 Gauge Wire From Circuit Breaker to Alternator B+
 - Ground Wire From Alternator to Bellhousing Starboard Side Ground Stud
(Excluding engines with Balmar 100 amp alternators)

The following items are not effected by the Coast Guard Safety Recall. These service updates address several driveability enhancements with the 8.1L and 8.1L HO engines. Some engines may already incorporate some of the changes. The major symptoms associated with this update are higher than normal charging voltage, possible ECM tachometer failure and intermittent code 81.

Engines equipped with a Balmar 100 amp alternator need modification B and D only.

- B - Fuse Block Modification - Power Supply to Fuel Pump Relay (ALL engines)**
- C - Service Update SU2002-01 - Alternator/Wiring Harness Modification (Excluding engines with Balmar 100 amp alternators)**
(Included in this kit)
- D - Crankshaft Position Sensor Replacement - Install the most recent iteration of crank sensor (ALL engines)**

NOTE: A White tie strap, around the fuse block wires, is an indicator that all needed modifications, listed above, have been done on that engine harness (see illustration below). If the white tie strap is not on the fuse block wires, an inspection must be done to determine which modifications have been done, if any.

NOTE: A sample Warranty Fast Fax is attached to the end of this update. Failure codes, time and description has been provided. Copies can be made in order to submit for warranty. If your facility already has kits in stock, multiple serial numbers can be put on the same fast fax. If you do not have kits in stock, follow normal warranty procedures by filling out the fast fax and fax it into our warranty department.

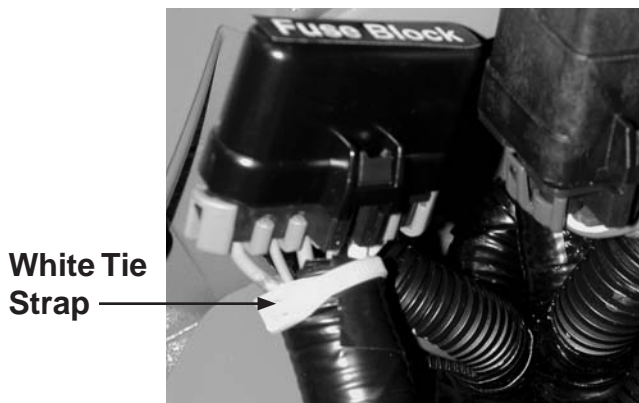

Published by Pleasurecraft Engine Group Training Services. Pleasurecraft's policy of continued improvement creates dated information and necessitates changes in procedures, specifications and methods used in trouble shooting and repair. In the event you have any questions regarding any of our products, the most up to date information may be obtained by contacting our service department to insure that any published information in your possession has not been updated. The information in the publication is believed to be true and correct at the time of publication. This publication is for informational purposes only and does not constitute a guarantee or warranty or in any way change or modify the written warranty, which is attached to PCM Products at the time of sale. The knowledge of this publication, the information revealed herein and/or the possession of this publication grants no license or authority to anyone to perform any action or make any statement or commitment, beyond the specific instructions stated herein, in behalf of or in the name of Pleasurecraft Engine Group. It is the sole responsibility of those using the information contained herein, to follow industry standard and common sense safety procedures when using the information contained herein and those using the information contained herein agree to defend and hold Pleasurecraft Engine Group harmless in all cases where injury and/or damage may occur during the use and/or application of the information contained herein.

Charging Circuit Modification (Bag A)

1. Disconnect the negative battery cable.
2. Remove the access cover.



3. Remove the two screws attaching the circuit breaker to the bracket.



4. Remove the ECM "J2" connector. Remove the relays from the bracket and move aside. Pull the circuit breaker up in order to access the terminals.

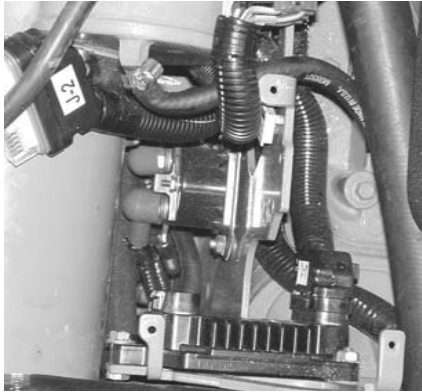

5. Remove the two attaching nuts/washers on the back of the circuit breaker. Remove the ORANGE 12 gauge wire and attach it on the same terminal as the RED/WHITE 10 gauge wire. Install the nut/washer and tighten securely.

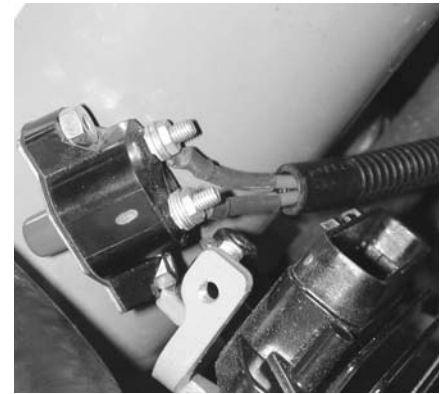

6. Attach the two RED 6 gauge wires (supplied in kit) to the other terminal. Install the nut/washer and tighten securely. The circuit breaker should now have one ORANGE and one RED/WHITE wire on one terminal, and the two RED 6 gauge wires on the other terminal. Install the circuit breaker onto the bracket and tighten the screws securely.



7. Remove the nut and lockwasher from the starter solenoid B+ terminal. Remove the ORANGE wire. Cut the ORANGE wire as far back in the harness as possible. Using electrical tape, tape the end of the wire to prevent any possible shorting to ground, or another circuit.

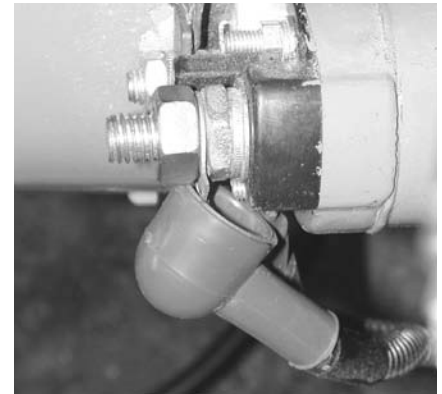

Important: A White tie strap must be attached around the fuse block wires as an indicator that all needed modifications from this service update have been completed.

Charging Circuit Modification (cont'd)

8. Route the fused RED 6 gauge wire from the circuit breaker to the starter solenoid B+ terminal. Install the nut and lockwasher and tighten securely.

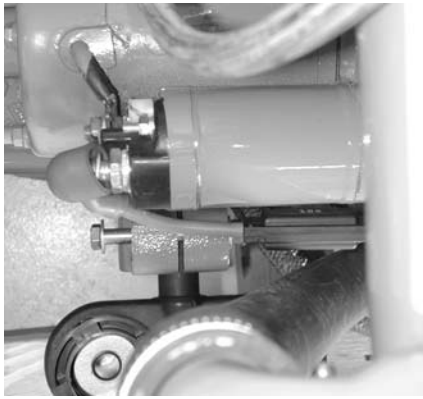

9. Using a 10 mm wrench, remove the ORANGE wire on the back of the alternator. Cut the ORANGE wire as far back in the harness as possible. Using electrical tape, tape the end of the wire to prevent any possible shorting to ground, or another circuit.



10. Route the long RED 6 gauge wire from the circuit breaker to the back of the alternator. Install the nut and lockwasher and tighten securely.

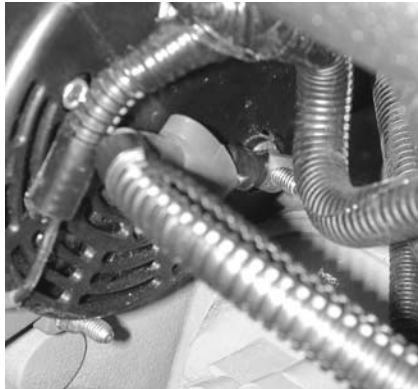

11. Using a 10 mm wrench, remove the BLACK wire on the back of the alternator. Cut the BLACK wire as far back in the harness as possible. Using electrical tape, tape the end of the wire to prevent any possible shorting to another circuit.

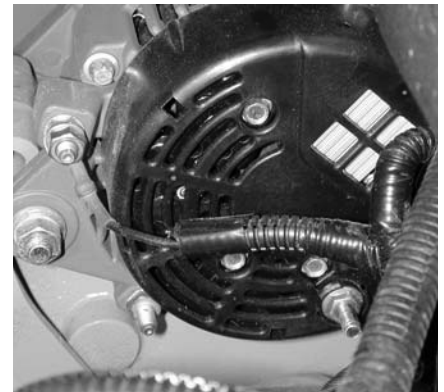

12. Attach the 6 gauge BLACK wire, provided in kit, to the back of the alternator ground stud. Route the wire in order to attach the other end to the bellhousing ground stud (ground stud located on the starter side of engine). Tighten securely.



13. Reattach the relays to the bracket.

14. Plug the ECM "J2" connector back into the ECM.

15. Reattach the access cover and tighten the screws securely.

16. Connect the negative battery cable.



Important: A White tie strap must be attached around the fuse block wires as an indicator that all needed modifications from this service update have been completed.

PCM Technical Support, Warranty and Dealer Assistance

Phone: (803) 345-0050

Fax: (800) 321-3797

Email: mschneider@pleasurecraft.com

dsoutherland@pleasurecraft.com

Fuse Block Modification (Bag B)

1. Remove the negative side battery terminal.
2. Remove the access cover in order to have access to the fuse block.
3. Remove fuse block from bracket and pull up in order to access the wires.
4. Remove the conduit/flex from the fuse block take-out.
5. Cut the PURPLE wire coming from terminal "A" of the fuse block as far down the harness as possible.
6. Use the small diameter heat shrink provided in order to seal off the cut wire on the main harness side. Using a heat gun, heat the shrink wrap in order to seal off the exposed wire.
7. The PURPLE wire coming from terminal "A" of the fuse block needs to be spliced into the RED/WHITE wire coming from terminal "E" of the fuse block.

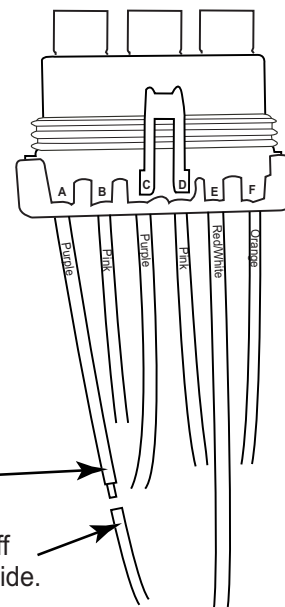
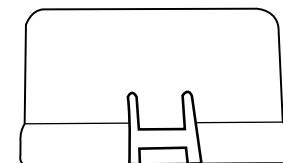

Cut Purple wire (from terminal "A").

Heat Shrink to seal off cut wire on harness side.

8. Cut the RED/WHITE wire coming from terminal "E," about the same distance down the harness as the PURPLE wire was cut.
9. Slide the larger shrink wrap, provided in the kit, over the RED/WHITE and the PURPLE wire.
10. Using the splice connector, provided in the kit, splice both ends of the RED/WHITE wire with the PURPLE wire from terminal "A."

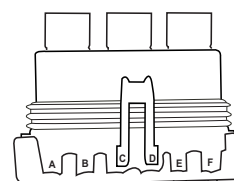
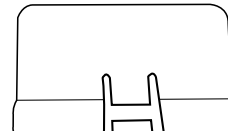

After Repair has been made, install a WHITE tie strap around the the wires.

11. Slide the shrink wrap over the splice connector. Using a heat gun, heat the shrink wrap in order to seal the connection.
12. Install the conduit/flex onto the fuse block take-out. Using electrical tape, tape the conduit/flex at both ends.
13. Install the white tie strap, provided in kit, around the fuse block wires and cut the access off.
14. Install the fuse block onto the bracket.
15. Connect negative battery cable.

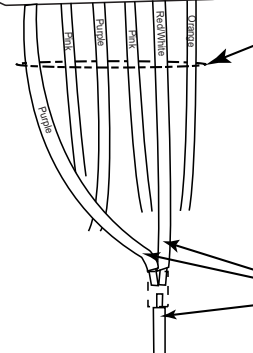

Splice purple wire from terminal "A" to the RED/WHITE wire from terminal "E". Shrink wrap after repair

Important: A White tie strap must be attached around the fuse block wires as an indicator that all needed modifications from this service update have been completed.

PCM Service Update

#SU2002-01

Alternator/Wiring Harness Modification (Bag C)

June 2002

SERVICE KIT # RK101014

1. Remove the negative side battery terminal.
2. Disconnect the 2-terminal connector from back of the alternator.
3. Verify the PURPLE/WHITE wire is in terminal "B."
4. If the PURPLE/WHITE wire is in terminal "B," proceed with step (5). If not, contact technical assistance at 803-345-0050.
5. Using a small screwdriver, or pick, carefully slide the rubber seal back out of the connector body.
6. Remove the black plastic plug from cavity "A" and discard.
7. Take the red wire, provided in kit, and insert the unterminated end through the front of the connector into cavity "A." Make sure that the terminal is entering the connector in the correct orientation. The terminal will only go in one way, DO NOT force it. Pull the wire until the terminal locks into the connector. If locked correctly, you will not be able to push the wire and terminal back out.
8. Insert unterminated end through the seal. You may have to twist the wires to avoid catching on the seal. Push the seal back up into the connector body.
9. Reconnect the 2-terminal plug to the back of the alternator.
10. Remove the 10 mm nut securing the 6 ga. RED wire to the back of the alternator.
11. Slide the unterminated end through the red boot along with the 6 ga. wire.
12. Strip the insulation off the unterminated end and crimp on the 1/4" ring terminal provided in the kit.
13. Install both ring terminals back onto the positive post of the alternator. Tighten the 10 mm nut. Slide the red boot over the terminal.
14. Reconnect negative battery cable.

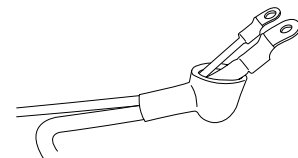
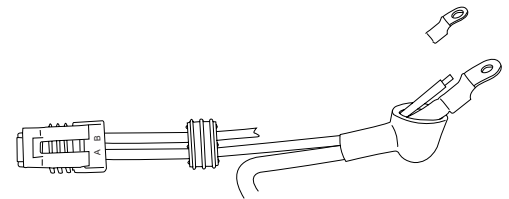
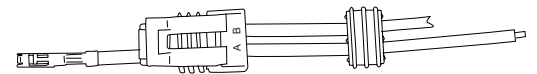
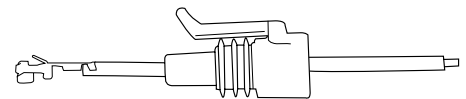
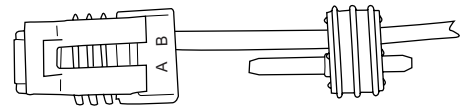
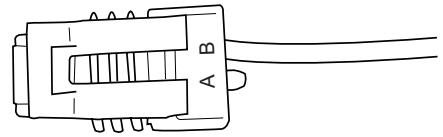

Important: A White tie strap must be attached around the fuse block wires as an indicator that all needed modifications from this service update have been completed.

Crankshaft Position Sensor Replacement (Bag D)

Important: The crankshaft position sensor is designed to contact the reluctor wheel of the crankshaft. Wear may be noticeable on the end of the sensor.

1. Remove the crankshaft position sensor electrical connector.

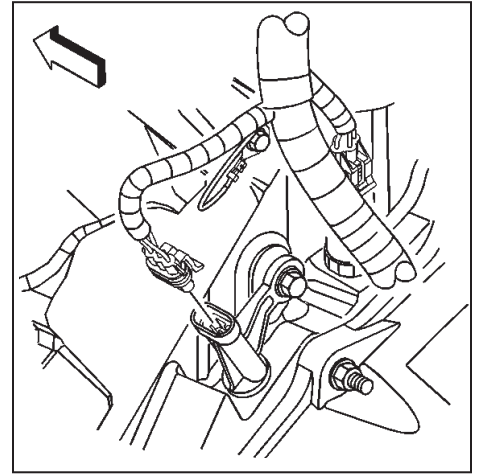

2. Remove the crankshaft position sensor bolt.
3. Apply penetrating oil to the crankshaft position sensor-to-engine block mating surface. Allow the penetrating oil to soak for several minutes, to help loosen the O-ring from the engine block.
4. Remove the crankshaft position sensor.

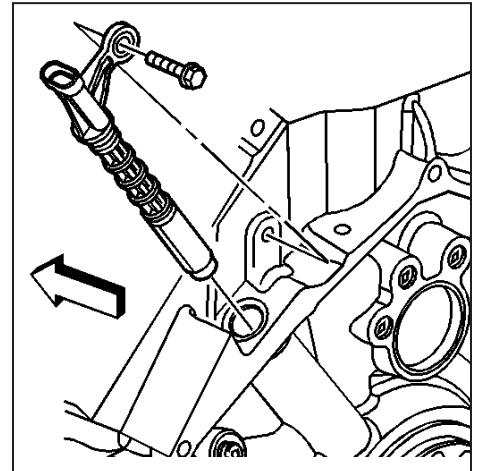

Important: Ensure that the crankshaft position sensor is fully seated against the crankshaft reluctor ring. The upper flange on the sensor **MAY NOT** seat against the engine block. The sensor is designed to wear to zero tolerance against the reluctor ring. The sensor is designed to be removed and installed three times. Exceeding three installations with the same sensor may result in engine driveability problems or a possible no-start.

Important: The crankshaft position sensor bolt has a thread sealant applied to the threads. The thread sealant may have come off during the removal of the bolt. Ensure that the bolt holes is clean of any debris before installing the crankshaft sensor bolt.

5. Install the crankshaft position sensor into the engine block. There may be a slight resistance as the O-ring seats into the engine block.
6. Apply thread sealer GM P/N 12345493 or equivalent to the crankshaft position sensor bolt.
7. Install the crankshaft position sensor bolt.

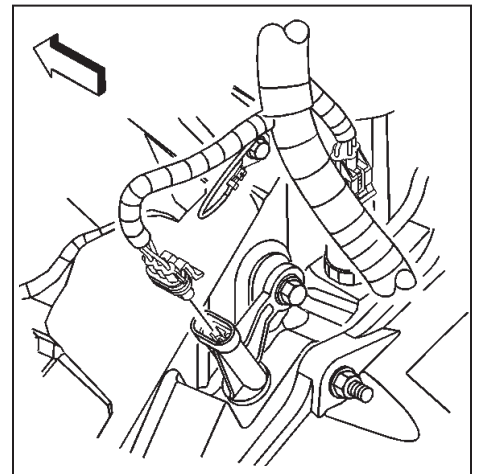

Tighten

Tighten the crankshaft position sensor bolt to 12 N·m (106 lb in).

Important: A White tie strap must be attached around the fuse block wires as an indicator that all needed modifications from this service update have been completed.



FASTFAX WARRANTY CLAIM APPLICATION

1-800-321-3797

ENGINE # _____
PCM CLAIM # _____

ENG SERIAL # _____
 MODEL _____
 TRANS # _____
 TRANS. MODEL# _____
 DATE OF SALE: ____/____/____ ENG HRS _____
 DATE OF FAILURE: ____/____/____
 BOAT HULL TYPE: _____

DATE: ____/____/____ DEALER # _____
 DEALER NAME/ _____ TECH or CONTACT: _____
 PHONE: _____ FAX: _____
 ADDRESS: _____

OWNER: _____ PHONE: _____
 ADDRESS: _____

DESCRIPTION OF PROBLEM:

QTY.	PART #	DESCRIPTION	COST	QTY.	PART #	DESCRIPTION	COST

LABOR OP. #	TIME ALLOW.	LABOR EXT.	FAIL CODE	LABOR OPERATION DESCRIPTION	PARTS:
	1.5 hrs			Wiring Harness Modification A, B and C	STOCK PARTS ADD 10%:
	0.5 hrs			R&R Crankshaft Position Sensor	LABOR:
					RETURN FREIGHT:
					CLAIM TOTAL:

NOTE TO DEALER: A COPY OF THIS CLAIM MUST BE RETURNED WITH DEFECTIVE PART IN 30 DAYS OR CLAIM WILL BE DENIED. RETURN PARTS TO: 1737 US HWY 76, LITTLE MOUNTAIN, SC 29075. CLAIM MUST BE SIGNED BY DEALER REPRESENTATIVE CONFIRMING OWNERS CONSENT FOR REPAIR. MAXIMUM RATE PAID TO DEALERS WHO DO NOT MEET REQUIREMENTS FOR 100% REIMBURSEMENT WILL BE PAID AT \$ 40.00 PER HOUR.

X _____
 DEALER'S SIGNATURE (REQUIRED)

APPROVED DENIED PARTS RETURN REQUIRED: YES NO

PARTS SUPPLIED BY: DEALER () DISTRIBUTOR () MANUFACTURER () AUTH. LABOR RATE: _____ WCLAIM # _____

SOLD TO: CUST.# _____ SHIP TO: CUST.# _____ NDA () 2 DAY SELECT () 3 DAY () GOD ()
 TERMS: _____ DISCOUNT: _____ SHIPPING INSTRUCTIONS: GRD () NDA () 2 DAY SELECT () 3 DAY () GOD () OTHER ()

PCM ORDER # _____